

SMD (AEC-Q200) 白金測温抵抗体 / DIN EN 60751

温度範囲 -50 °C ~ +130 °C (150 °C*)

SMDは低コストが求められる量産向けプリント基板自動実装タイプの薄膜型測温抵抗体です。長期安定性、互換性が特長です。

公称抵抗値 R_0 [Ω]	公差クラ	タイプ	品番	梱包	寸法と公差 (mm)
Pt1000	F 0.3 (B)	0603	50 348 87	Blister reel	L1: 1.7 \pm 0.2 L2: 0.3 \pm 0.2 W: 0.9 \pm 0.2 H: 0.45 \pm 0.1
Pt1000	F 0.3 (B)	0805	50 348 86	Blister reel	L1: 2.3 \pm 0.2 L2: 0.3 \pm 0.2 W: 1.4 \pm 0.2 H: 0.6 \pm 0.1
Pt1000	F 0.3 (B)	1206	50 348 85	Blister reel	L1: 3.2 +0.2 -0.3 L2: 0.5 \pm 0.25 W: 1.6 \pm 0.2 H: 0.6 \pm 0.1

公差クラスの温度範囲

公差クラス F 0.3 (B) -50 °C ~ +130 °C

* (膨張係数が適合する材料の回路基板の場合、最大+150°Cまで使用可能)

温度係数

TCR = 3850 ppm/K

応答性

水流 ($v = 0.4$ m/s)

$t_{0.5} = 0.1$ s

$t_{0.9} = 0.25$ s

空気中 ($v = 2$ m/s)

$t_{0.5} = 2.5$ s

$t_{0.9} = 8$ s

測定電流

Pt1000 Ω : 0.1 ~ 0.3 mA

(自己発熱を考慮する必要があります)

長期安定性

記述した上限温度で1000時間使用後の0 °Cでのドリフトは、DIN EN 60751の公差クラスの許容値を超えることはありません。

自己発熱

0.8 K/mW at 0 °C

接続端子

ガルバニックスズめつき端子 (ニッケル層)

接合技術

フェイスアップ実装: リフローはんだ, またはウェーブはんだ (例: ダブルウェーブはんだ ≤ 8 s/235 °C)

梱包

プリスターリール "フェイスアップ" 4000 pcs/ reel.

その他梱包についてはご相談に応じます

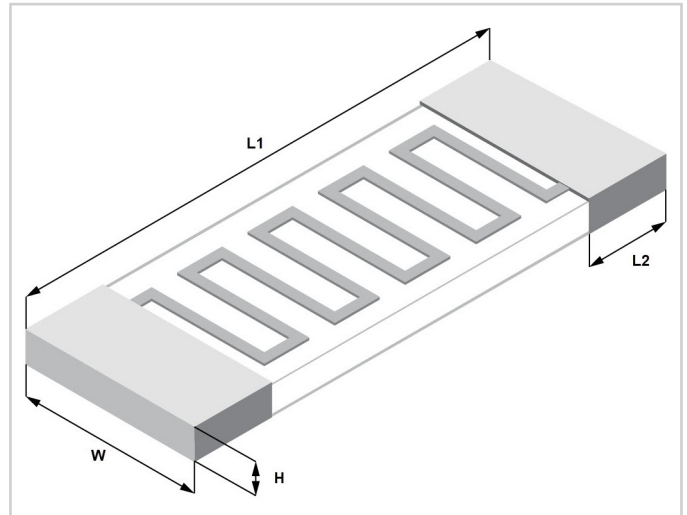

Image for illustration purposes only
Color, shape and forming of metallization may vary

保管期間

推奨条件下で保管した場合、製造後最低9か月。お客様の再認定による保管条件によっては、保管期間が長くなる可能性があります。窒素雰囲気推奨。

備考

各種公差, 抵抗値についてはご相談に応じます

SMD (AEC-Q200) 白金測温抵抗体 / DIN EN 60751

温度範囲 -50 °C ~ +130 °C (150 °C*)

AEC-Q200, Rev. D - Qualification Matrix for Pt1000 SMD 0603, Pt1000 0805, Pt1000 1206

All tests are performed by an ISO 17025 certified laboratory.

Item	Standard	Test Conditions / Methods	Specifications
High Temperature Exposure (Storage)	MIL-STD-202 Method 108	Test temp.: 125 °C ± 3 °C Duration: 500 hours unpowered Measurement at 24 hours ± 2 hours after test conclusion	No visible damage $\left \frac{\Delta R_0}{R_0} \right \leq 0.1 \%$
Temperature Cycling	JESD22 Method JA-104	Test temp.: -55 °C / +125 °C (+10 °C / -0 °C) Soak time at lower or upper temp.: 30 min Number of cycles: 1000 Measurement at 24 hours ± 2 hours after test conclusion	No visible damage $\left \frac{\Delta R_0}{R_0} \right \leq 0.1 \%$
Biased Humidity	MIL-STD-202 Method 103	Test temp.: 85 °C ± 2 °C Rel. humidity of air: 85 % ± 3 % Duration: 1000 hours Measurement at 24 hours ± 2 hours after test conclusion	No visible damage $\left \frac{\Delta R_0}{R_0} \right \leq 0.1 \%$
Operational Life	MIL-STD-202 Method 108	Test temp.: 125 °C ± 3 °C Duration: 1000 hours Measurement at 24 hours ± 2 hours after test conclusion	No visible damage $\left \frac{\Delta R_0}{R_0} \right \leq 0.1 \%$
External Visual	MIL-STD-883 Method 2009	Inspect device construction, marking and workmanship	No visible damage
Physical Dimension	JESD22 Method JB-100	Verify physical dimensions to the applicable device specification	Within the specified values
Resistance to Solvents	MIL-STD-202 Method 215	Per MIL-STD-202 Method 215 2 parts solvent A, 2 parts solvent B, 1 part solvent D (brushed)	No visible damage
Mechanical Shock	MIL-STD-202 Method 213	Test Condition F Acceleration: 1500 g Half sine waveform Duration: 0.5 ms 3 shocks per direction, 6 directions at room temperature	No visible damage $\left \frac{\Delta R_0}{R_0} \right \leq 0.1 \%$
Vibration	MIL-STD-202 Method 204	Acceleration: 5 g Cycle time: 20 min Frequency range: 10 to 2000 Hz 12 cycles per axis 3 axes at room temperature	No visible damage $\left \frac{\Delta R_0}{R_0} \right \leq 0.1 \%$
Resistance to Soldering Heat	MIL-STD-202 Method 210	Condition B - No pre-heat of samples. Temp.: 260 °C ± 5 °C, Time: 10 s ± 1 s, 1 cycle	No visible damage $\left \frac{\Delta R_{RT}}{R_{RT}} \right \leq 0.5 \%$

SMD (AEC-Q200) 白金測温抵抗体 / DIN EN 60751

温度範囲 -50 °C ~ +130 °C (150 °C*)

AEC-Q200, Rev. D - Qualification Matrix for Pt1000 SMD 0603, Pt1000 0805, Pt1000 1206

All tests are performed by an ISO 17025 certified laboratory.

Item	Standard	Test Conditions / Methods	Specifications
ESD	AEC-Q200-002	Stress levels: 500V, 1000V, 2000V, 4000V, 6000V, 8000V, 12000V, 16000V, 25000V Zaps & Polarities: 1 zap, positive and negative per pin	SMD 0603: Product passed the component classification level 4 (4000 V) SMD 0805: Product passed the component classification level 3 (2000 V) SMD 1206: Product passed the component classification level 6 (8000 V)
Solderability	J-STD-002	a) Test condition J-STD-002D, condition B Ageing: 155 °C dry heat, 4 h Soldering temperature: 235 °C Dwell time: 5 s Flux: ROL 1 Solder bath: SnPb b) Test condition J-STD-002D, condition B, category C Ageing: Steam, 8 h Soldering temperature: 215 °C Dwell time: 5 s Flux: ROL 1 Solder bath: SnPb c) Test condition J-STD-002D, condition D, category C Ageing: Steam, 8 h Soldering temperature: 260 °C Dwell time: 30 s Flux: ROL 1 Solder bath: SnPb	Min. 95 % of termination is covered by solder
Electrical Characterization	Specifications	a) T1 = 0 °C b) T2 = -40 °C c) T3 = 130 °C	Within the specified values
Board Flex	AEC-Q200-005	Bending of board: 2mm (Min.) Duration: 60 (+5) s	No visible damage $\left \frac{\Delta R_{RT}}{R_{RT}} \right \leq 0.5 \%$
Terminal Strength	AEC-Q200-006	Applied force: 1.8 kg (17,7N) Duration of the applied forces: 60 (+1) s	No visible damage $\left \frac{\Delta R_{RT}}{R_{RT}} \right \leq 0.5 \%$

SMD (AEC-Q200) 白金測温抵抗体 / DIN EN 60751

温度範囲 -50 °C ~ +130 °C (150 °C*)

YAGEO Nexensos internal test

Item	Standard	Test Conditions / Methods
Multiple Solderability	According to IPC/JEDEC J-STD-020E norm	According to internal Heraeus tests, the component is suitable for 3 heat cycles (reflow soldering) with > 60 seconds above liquidus (217 °C)



The information provided in this data sheet describes certain technical characteristics of the product, but shall not be qualified or construed as quality guarantee (Beschaffenheitsgarantie) in the meaning of sections 443 and 444 German Civil Code. The information provided in this data sheet regarding measurement values (including, but not limited to, response time, long-term stability, vibration and shock resistance, insulation resistance and self-heating) are average values that have been obtained under laboratory conditions in tests of large numbers of the product. Product results or measurements achieved by customer or any other person in any production, test, or other environment may vary depending on the specific conditions of use. The customer is solely responsible to determine whether the product is suited for the customer's intended use; in this respect YAGEO Nexensos cannot assume any liability. The sale of any products by YAGEO Nexensos is exclusively subject to the General Terms of Sale and Delivery of YAGEO Nexensos in their current version at the time of purchase, which is available under www.yageo-nexensos.com/tc or may be furnished upon request. This data sheet is subject to changes without prior notice.

YAGEO Nexensos GmbH, Reinhard-Heraeus-Ring 23, 63801 Kleinostheim, Germany

YAGEO Nexensos GmbH, Germany
Web: www.yageo-nexensos.jp
お問い合わせ: nexensos.japan@yageo.com

Document: 20002513038 Part 003 Version 04 | Status: 03/2023

Page 4 of 4